

ITEM	PART NUMBER	REV	DESCRIPTION	DESCRIPTION 2	Qty
1	10044		RESS,14KW,LITHIUM ION PACK(A)	14KWH RESS PACK A SS	1
2	30032		WASHER, FLAT, M8X24MM OD	ZPS	10
3	30054		BOLT,FLANGE HEAD,M16X2.0X45MM	ZPS,GR 8.8	4
4	30055		NUT,FLANGE,M16X2.0MM	ZPS,GR 8.8	4
5	30069		BOLT,FLANGE HEAD,M8X1.25X20MM	ZPS,GR 8.8	10
6	40314	01	WELDMNT,RESS BKT,PACK A ASSY	BODY MOUNT,NATIONAL GRID	1
7	50061		ADAPTER,1/2NPT TO 10ORFS		1
8	50066		ADAPTER,3/4NPT TO 10ORFS		1
9	50069		HOSE END,90 DEG,10-10,PUSHLOC	ORFS,801 HOSE,SHORT DROP	2

01	INITIAL MANUFACTURING RELEASE	AJC	05/29/15
REV	DESCRIPTION OF CHANGE	REVISED BY	DATE

PROPRIETARY AND CONFIDENTIAL  
THE INFORMATION CONTAINED IN THIS DRAWING IS THE SOLE PROPERTY OF ODYNE SYSTEMS LLC. REPRODUCTION IN PART OR AS A WHOLE WITHOUT THE WRITTEN PERMISSION OF ODYNE IS PROHIBITED.

<small>UNLESS OTHERWISE SPECIFIED          REFERENCE DIMENSIONS SHOWN IN PARENTHESIS          DIMENSIONS ARE IN INCHES</small> ANGULAR ± 1.0° NOMINAL ± 0.125 ONE PLACE DECIMAL ± 0.060 TWO PLACE DECIMAL ± 0.030 THREE PLACE DECIMAL ± 0.010	<small>DRAWN</small> AJC 05/29/15		
	<small>MATERIAL</small>		
<small>FINISH</small>			<small>SHEET SIZE</small> B
<small>SCALE</small> 1:12			<small>SHEET 1 OF 3</small>

www.odyne.com

**SUB-ASSY,RESS,PACK A,BODY MNT  
 NATIONAL GRID STACKED RESS**

**70280**      **01**

DO NOT SCALE DRAWING

8 7 6 5 4 3 2 1

ITEM	PART NUMBER	REV	DESCRIPTION	DESCRIPTION 2	QTY.
14	30054		BOLT,FLANGE HEAD,M16X2.0X45MM	ZPS,GR 8.8	4
15	30055		NUT,FLANGE,M16X2.0MM	ZPS,GR 8.8	4

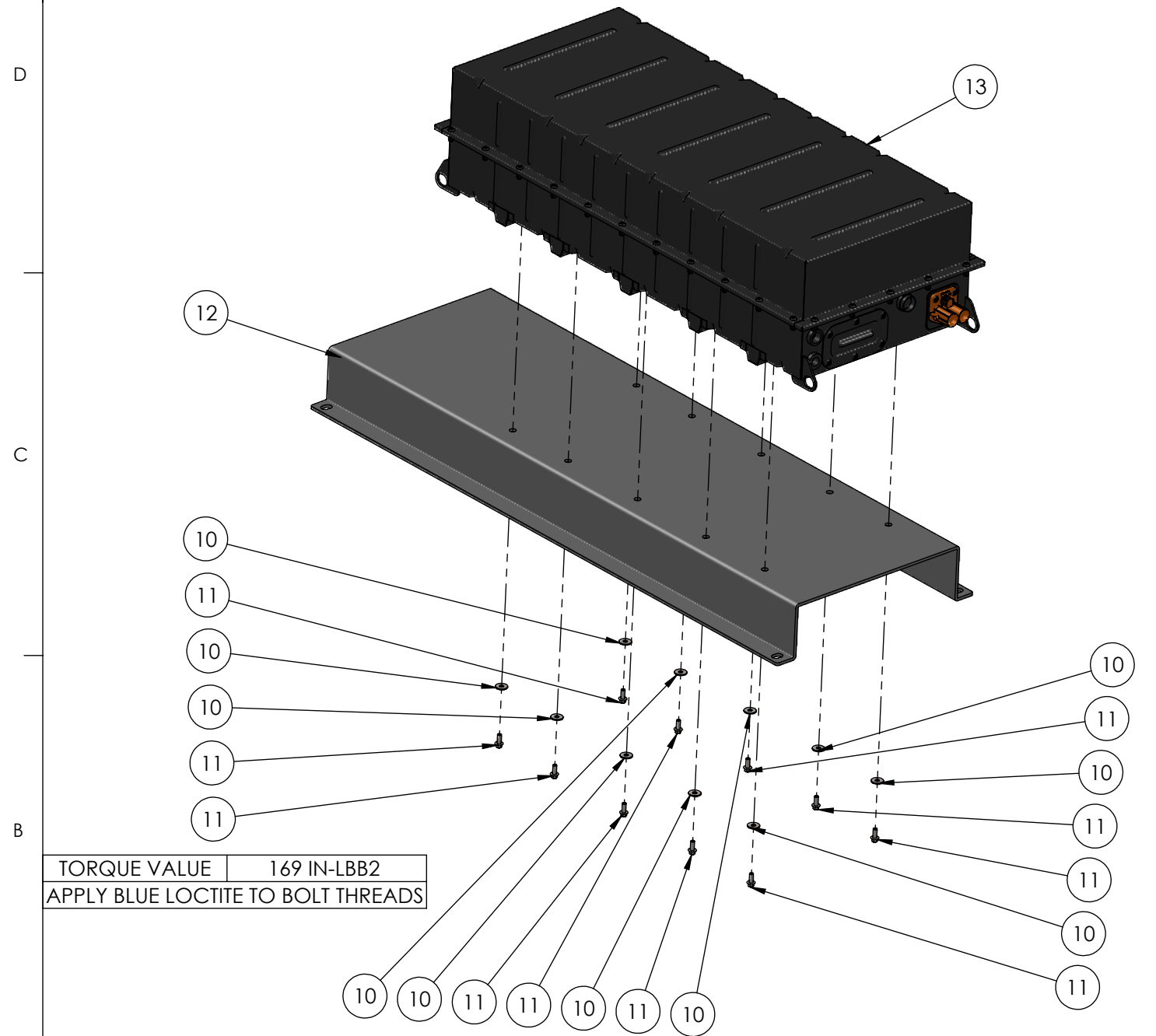

TORQUE VALUE 169 IN-LBB2  
APPLY BLUE LOCTITE TO BOLT THREADS

ITEM	PART NUMBER	REV	DESCRIPTION	DESCRIPTION 2	QTY.
10	30032		WASHER, FLAT, M8X24MM OD	ZPS	10
11	30069		BOLT,FLANGE HEAD,M8X1.25X20MM	ZPS,GR 8.8	10
12	40314	01	WELDMENT,RESS BKT,PACK A ASSY	BODY MOUNT,NATIONAL GRID	1
13	10044		RESS,14KW,LITHIUM ION PACK(A)	14KWH RESS PACK A SS	1

01	INITIAL MANUFACTURING RELEASE	AJC	05/29/15
REV	DESCRIPTION OF CHANGE	REVISED BY	DATE

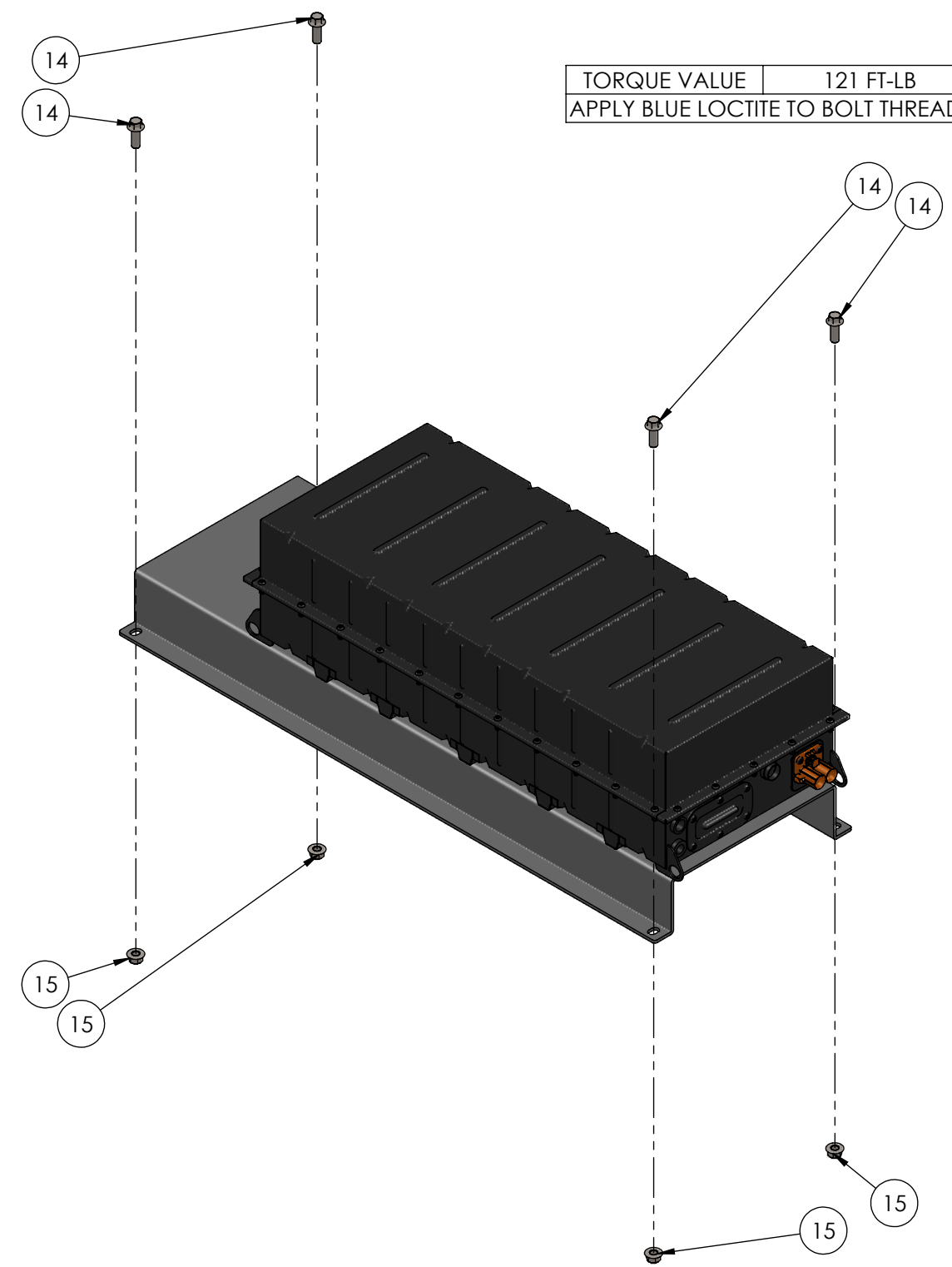

TORQUE VALUE 121 FT-LB  
APPLY BLUE LOCTITE TO BOLT THREADS

PROPRIETARY AND CONFIDENTIAL  
THE INFORMATION CONTAINED IN THIS DRAWING IS THE SOLE PROPERTY OF ODYNE SYSTEMS LLC. REPRODUCTION IN PART OR AS A WHOLE WITHOUT THE WRITTEN PERMISSION OF ODYNE IS PROHIBITED.

UNLESS OTHERWISE SPECIFIED  
REFERENCE DIMENSIONS SHOWN IN PARENTHESIS  
DIMENSIONS ARE IN INCHES

DRAWN	AJC	05/29/15
ANGULAR	± 1.0°	
NOMINAL	± 0.125	
ONE PLACE DECIMAL	± 0.060	
TWO PLACE DECIMAL	± 0.030	
THREE PLACE DECIMAL	± 0.010	

MATERIAL: INTERPRET GEOMETRIC TOLERANCE PER ASME Y14.5M-1994

FINISH:

**ODYNE**  
www.odyne.com

SUB-ASSY,RESS,PACK A,BODY MNT  
NATIONAL GRID STACKED RESS

SHEET SIZE	PART NUMBER	REV
B	70280	01
SCALE	DO NOT SCALE DRAWING	SHEET 2 OF 3
1:12		

8 7 6 5 4 3 2 1

ITEM	PART NUMBER	REV	DESCRIPTION	DESCRIPTION 2	QTY.
16	50061		ADAPTER,1/2NPT TO 10ORFS		1
17	50066		ADAPTER,3/4NPT TO 10ORFS		1
18	50069		HOSE END,90 DEG,10-10,PUSHLOC	ORFS,801 HOSE,SHORT DROP	2

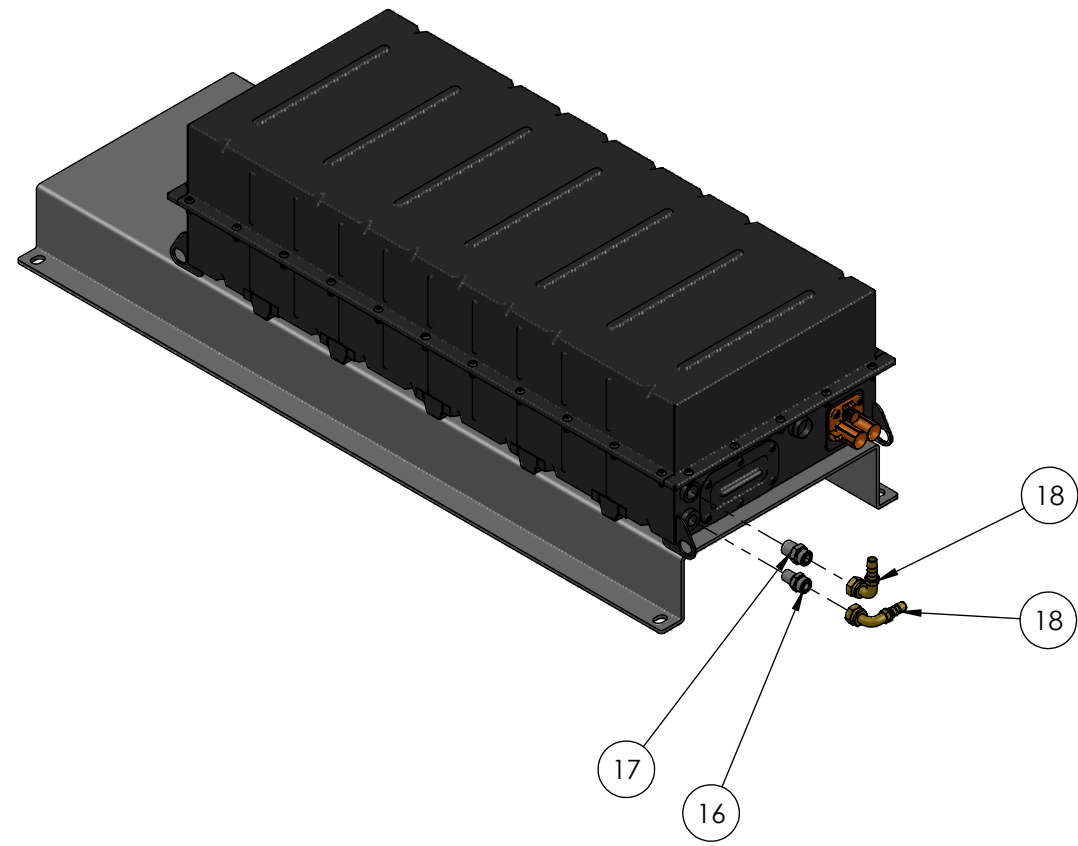

REV	DESCRIPTION OF CHANGE	REVISED BY	DATE
01	INITIAL MANUFACTURING RELEASE	AJC	05/29/15

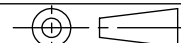
<p>PROPRIETARY AND CONFIDENTIAL  <small>THE INFORMATION CONTAINED IN THIS DRAWING IS THE SOLE PROPERTY OF ODYNE SYSTEMS LLC. REPRODUCTION IN PART OR AS A WHOLE WITHOUT THE WRITTEN PERMISSION OF ODYNE IS PROHIBITED.</small></p>				 <a href="http://www.odyne.com">www.odyne.com</a>		
<p>UNLESS OTHERWISE SPECIFIED  <small>REFERENCE DIMENSIONS SHOWN IN PARENTHESIS  DIMENSIONS ARE IN INCHES</small></p>		<p>DRAWN</p>	<p>AJC</p>	<p>05/29/15</p>	<p>SUB-ASSY,RESS,PACK A,BODY MNT  NATIONAL GRID STACKED RESS</p>	
<p>ANGULAR ± 1.0°  NOMINAL ± 0.125  ONE PLACE DECIMAL ± 0.060  TWO PLACE DECIMAL ± 0.030  THREE PLACE DECIMAL ± 0.010</p>						
<p>MATERIAL</p>		<p>INTERPRET GEOMETRIC TOLERANCE PER  ASME Y14.5M-1994</p>				<p>SHEET SIZE</p>
<p>FINISH</p>						<p>SCALE</p>
					<p>B</p>	<p>PART NUMBER</p>
					<p>1:12</p>	<p>70280</p>
					<p>DO NOT SCALE DRAWING</p>	<p>REV</p>
					<p>SHEET 3 OF 3</p>	<p>01</p>