

ITEM	PART NUMBER	REV	DESCRIPTION	DESCRIPTION 2	Qty
1	10045		RESS,14KW,LITHIUM ION PACK(B)	14KWH RESS PACK B CS	1
2	30032		WASHER, FLAT, M8X24MM OD	ZPS	10
3	30054		BOLT,FLANGE HEAD,M16X2.0X45MM	ZPS,GR 8.8	10
4	30055		NUT,FLANGE,M16X2.0MM	ZPS,GR 8.8	4
5	30069		BOLT,FLANGE HEAD,M8X1.25X20MM	ZPS,GR 8.8	10
6	40237	02	BRACKET,RESS WELDMENT ASSY	JCI RESS,REMOVABLE DESIGN	1
7	40243	03	BRACKET,MOUNTING,RESS	JCI RESS,REMOVABLE DESIGN	2
8	50061		ADAPTER,1/2NPT TO 10ORFS		1
9	50066		ADAPTER,3/4NPT TO 10ORFS		1
10	50068		HOSE END,45 DEG,10-10,PUSHLOC	ORFS,801 HOSE	2

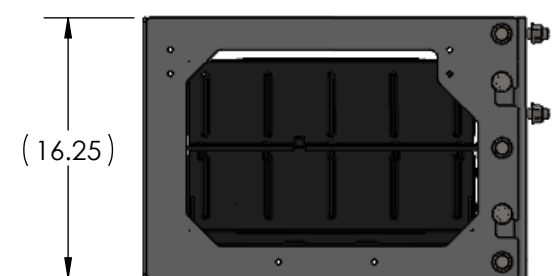
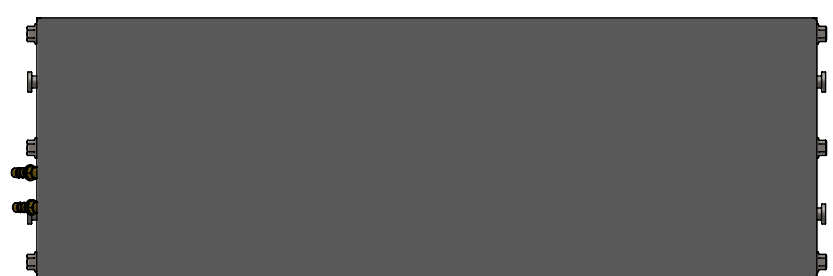
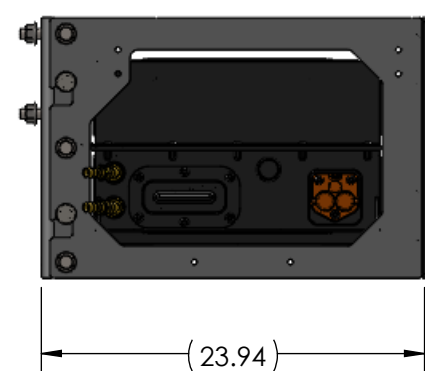
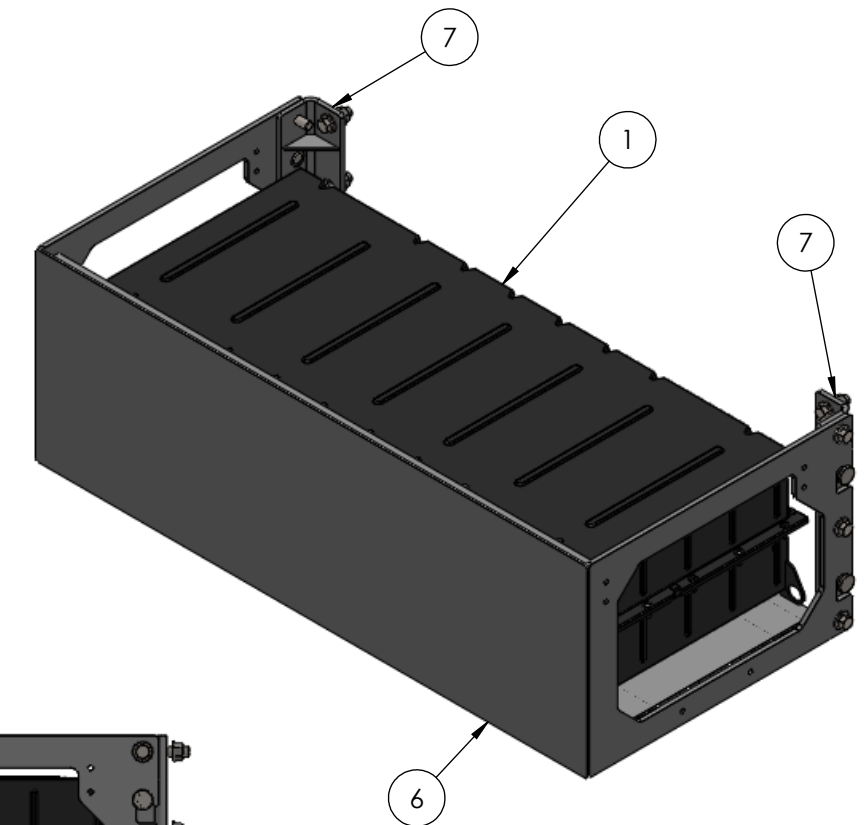
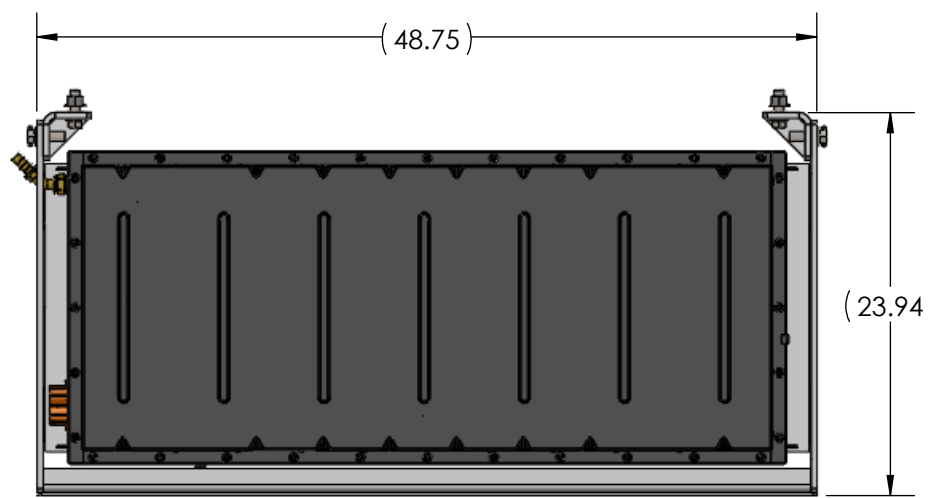

REV	DESCRIPTION OF CHANGE	REVISED BY	DATE
03	REPLACED PART #30149 WITH PART #30054	AJC	02/18/15

PROPRIETARY AND CONFIDENTIAL THE INFORMATION CONTAINED IN THIS DRAWING IS THE SOLE PROPERTY OF ODYNE SYSTEMS LLC. REPRODUCTION IN PART OR AS A WHOLE WITHOUT THE WRITTEN PERMISSION OF ODYNE IS PROHIBITED.			
UNLESS OTHERWISE SPECIFIED REFERENCE DIMENSIONS SHOWN IN PARENTHESIS DIMENSIONS ARE IN INCHES	DRAWN	AJC	04/09/14
ANGULAR ± 1.0° NOMINAL ± 0.125 ONE PLACE DECIMAL ± 0.060 TWO PLACE DECIMAL ± 0.030 THREE PLACE DECIMAL ± 0.010			
MATERIAL	INTERPRET GEOMETRIC TOLERANCE PER ASME Y14.5M-1994		
FINISH			

 www.odyne.com		
SUB-ASSY,RESS,CS,G2V2 PIE WAGN JCI RESS,REMOVABLE DESIGN		
SHEET SIZE	PART NUMBER	REV
B	70261	03
SCALE	DO NOT SCALE DRAWING	SHEET 1 OF 4
1:12		

D
C
B
A

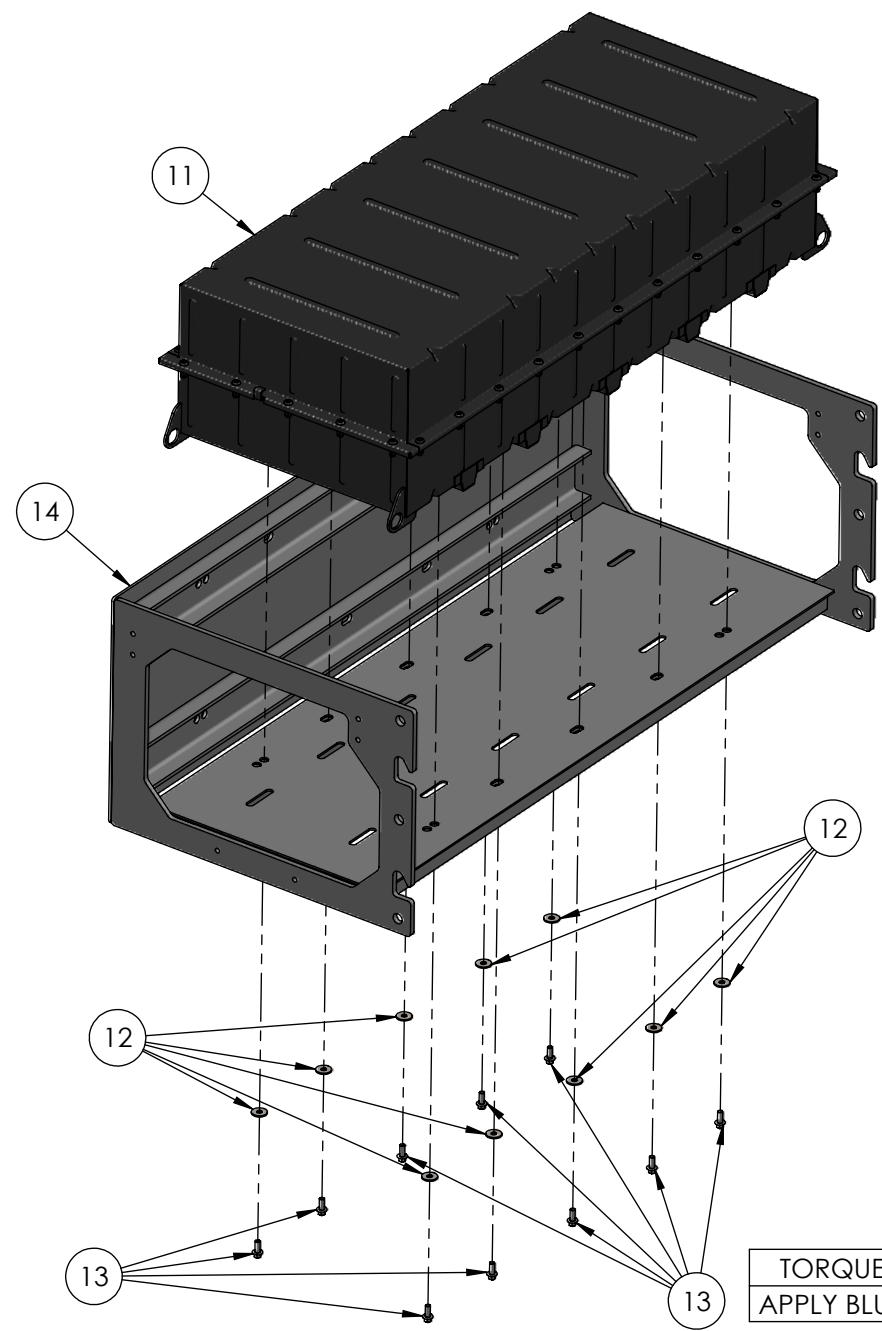

TORQUE VALUE	169 IN-LB
APPLY BLUE LOCTITE TO BOLT THREADS	

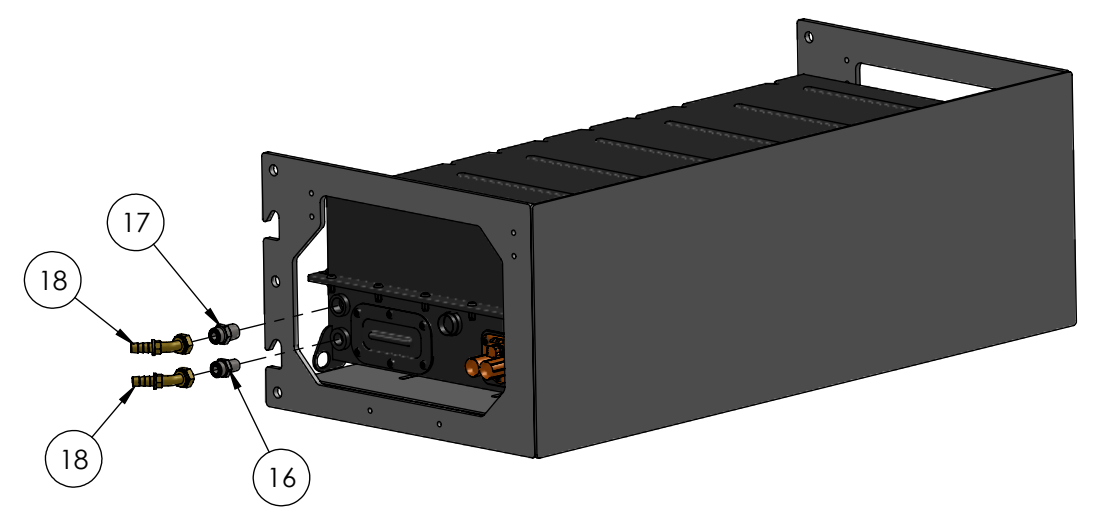

ITEM	PART NUMBER	REV	DESCRIPTION	DESCRIPTION 2	Qty
15	10045		RESS,14KW,LITHIUM ION PACK(B)	14KWH RESS PACK B CS	1
16	50061		ADAPTER,1/2NPT TO 10ORFS		1
17	50066		ADAPTER,3/4NPT TO 10ORFS		1
18	50068		HOSE END,45 DEG,10-10,PUSHLOC	ORFS,801 HOSE	2

ITEM	PART NUMBER	REV	DESCRIPTION	DESCRIPTION 2	Qty
11	10045		RESS,14KW,LITHIUM ION PACK(B)	14KWH RESS PACK B CS	1
12	30032		WASHER, FLAT, M8X24MM OD	ZPS	10
13	30069		BOLT,FLANGE HEAD,M8X1.25X20MM	ZPS,GR 8.8	10
14	40237	02	BRACKET,RESS WELDMNT ASSY	JCI RESS,REMOVABLE DESIGN	1

BATTERY INSTALLATION

03	REPLACED PART #30149 WITH PART #30054	AJC	02/18/15
REV	DESCRIPTION OF CHANGE	REVISED BY	DATE

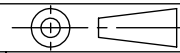
PROPRIETARY AND CONFIDENTIAL <small>THE INFORMATION CONTAINED IN THIS DRAWING IS THE SOLE PROPERTY OF ODYNE SYSTEMS LLC. REPRODUCTION IN PART OR AS A WHOLE WITHOUT THE WRITTEN PERMISSION OF ODYNE IS PROHIBITED.</small>				 www.odyne.com	
UNLESS OTHERWISE SPECIFIED REFERENCE DIMENSIONS SHOWN IN PARENTHESIS DIMENSIONS ARE IN INCHES ANGULAR ± 1.0° NOMINAL ± 0.125 ONE PLACE DECIMAL ± 0.060 TWO PLACE DECIMAL ± 0.030 THREE PLACE DECIMAL ± 0.010	DRAWN AJC 04/09/14			SUB-ASSY,RESS,CS,G2V2 PIE WAGN JCI RESS,REMOVABLE DESIGN	
MATERIAL	INTERPRET GEOMETRIC TOLERANCE PER ASME Y14.5M-1994		SHEET SIZE	PART NUMBER	REV
FINISH			B	70261	03
			SCALE	DO NOT SCALE DRAWING	SHEET 2 OF 4

ITEM	PART NUMBER	REV	DESCRIPTION	DESCRIPTION 2	Qty
19	30054		BOLT,FLANGE HEAD,M1 6X2.0X45MM	ZPS,GR 8.8	6
20	40237	02	BRACKET,RESS WELDMENT ASSY	JCI RESS,REMOVABLE DESIGN	1
21	40243	03	BRACKET,MOUNTING,RESS	JCI RESS,REMOVABLE DESIGN	2

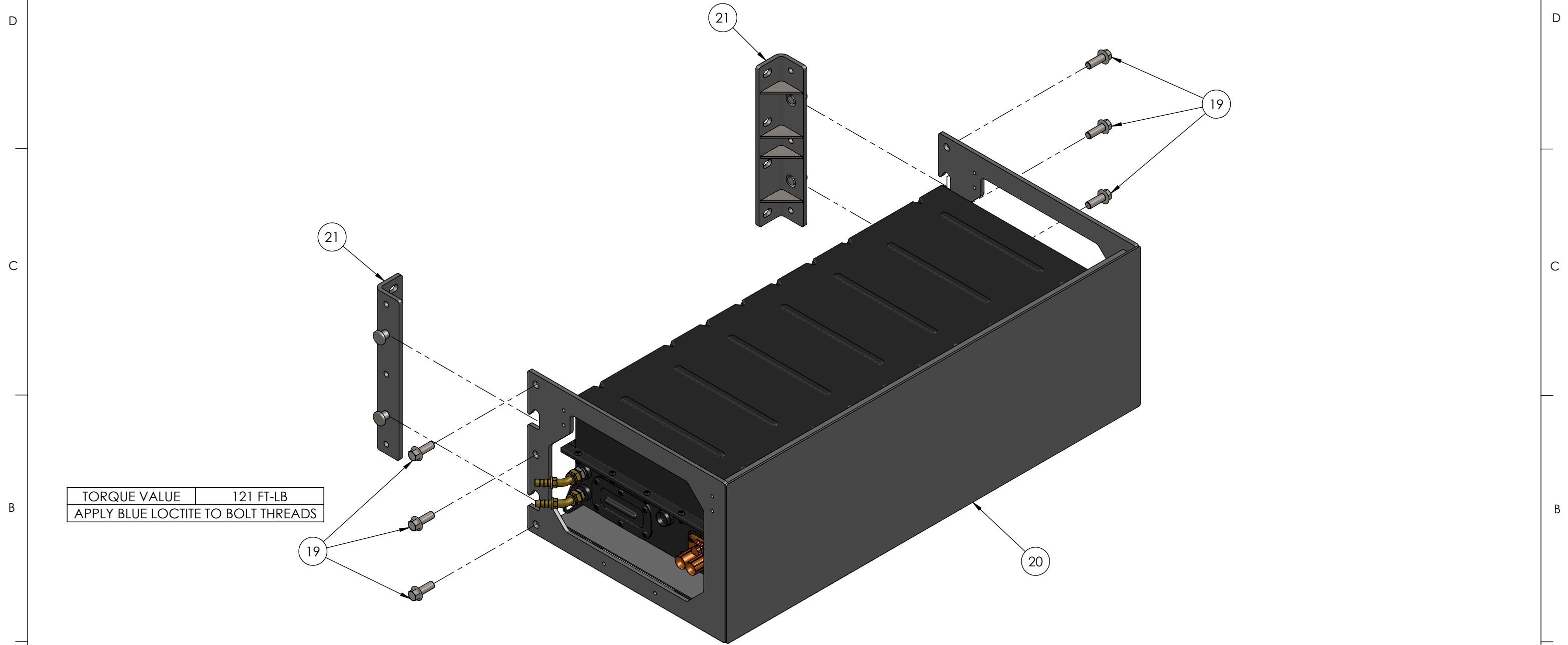

TORQUE VALUE	121 FT-LB
APPLY BLUE LOCTITE TO BOLT THREADS	

MOUNTING BRACKET INSTALLATION

03	REPLACED PART #30149 WITH PART #30054	AJC	02/18/15
REV	DESCRIPTION OF CHANGE	REVISED BY	DATE

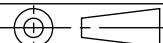
PROPRIETARY AND CONFIDENTIAL <small>THE INFORMATION CONTAINED IN THIS DRAWING IS THE SOLE PROPERTY OF ODYNE SYSTEMS LLC. REPRODUCTION IN PART OR AS A WHOLE WITHOUT THE WRITTEN PERMISSION OF ODYNE IS PROHIBITED.</small>				 www.odyne.com	
<small>UNLESS OTHERWISE SPECIFIED REFERENCE DIMENSIONS SHOWN IN PARENTHESIS DIMENSIONS ARE IN INCHES</small>	<small>DRAWN</small> AJC	<small>AJC</small>	<small>04/09/14</small>	SUB-ASSY,RESS,CS,G2V2 PIE WAGN JCI RESS,REMOVABLE DESIGN	
<small>ANGULAR ± 1.0° NOMINAL ± 0.125 ONE PLACE DECIMAL ± 0.060 TWO PLACE DECIMAL ± 0.030 THREE PLACE DECIMAL ± 0.010</small>	<small>INTERPRET GEOMETRIC TOLERANCE PER ASME Y14.5M-1994</small>			<small>SHEET SIZE</small> B	<small>PART NUMBER</small> 70261
<small>MATERIAL</small>	<small>FINISH</small> 			<small>REV</small> 03	<small>SHEET 3 OF 4</small>
<small>SCALE 1:8</small>				<small>DO NOT SCALE DRAWING</small>	

ITEM	PART NUMBER	REV	DESCRIPTION	DESCRIPTION 2	Qty
22	30054		BOLT,FLANGE HEAD,M1 6X2.0X45MM	ZPS,GR 8.8	4
23	30055		NUT,FLANGE,M1 6X2.0MM	ZPS,GR 8.8	4

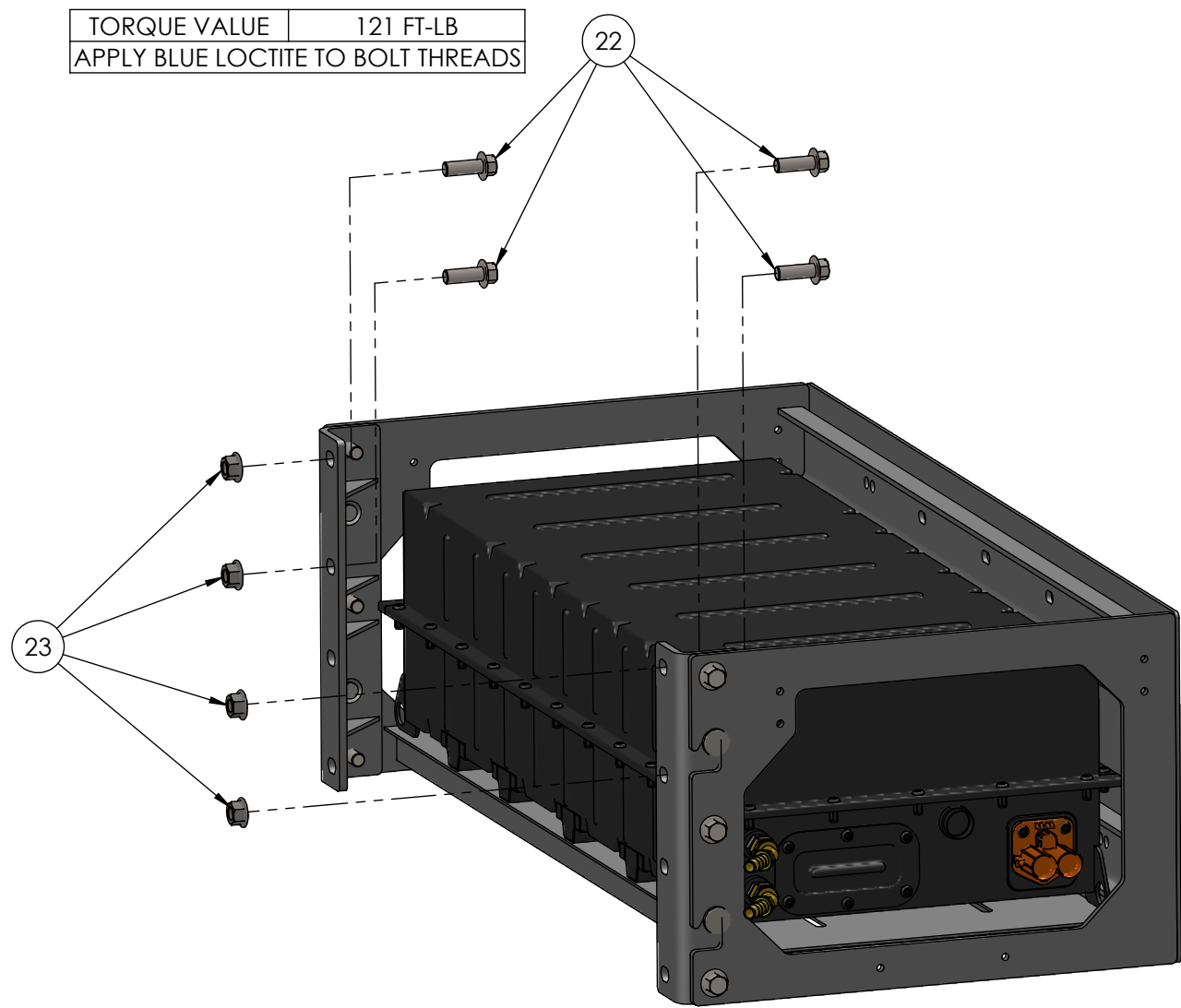

REV	DESCRIPTION OF CHANGE	REVISED BY	DATE
03	REPLACED PART #30149 WITH PART #30054	AJC	02/18/15

PROPRIETARY AND CONFIDENTIAL
THE INFORMATION CONTAINED IN THIS DRAWING IS THE SOLE PROPERTY OF ODYNE SYSTEMS LLC. REPRODUCTION IN PART OR AS A WHOLE WITHOUT THE WRITTEN PERMISSION OF ODYNE IS PROHIBITED.

UNLESS OTHERWISE SPECIFIED REFERENCE DIMENSIONS SHOWN IN PARENTHESIS DIMENSIONS ARE IN INCHES	DRAWN	AJC	04/17/14
ANGULAR ± 1.0°			
NOMINAL ± 0.125			
ONE PLACE DECIMAL ± 0.060			
TWO PLACE DECIMAL ± 0.030			
THREE PLACE DECIMAL ± 0.010			

MATERIAL INTERPRET GEOMETRIC TOLERANCE PER ASME Y14.5M-1994

FINISH

ODYNE
www.odyne.com

SUB-ASSY,RESS,CS,G2V2 PIE WAGN
JCI RESS,REMOVABLE DESIGN

SHEET SIZE	PART NUMBER	REV
B	70261	03
SCALE 1:8	DO NOT SCALE DRAWING	SHEET 4 OF 4